



FUEL MANAGEMENT SYSTEMS



DISPENSERS



KITS



PUMPS



METERS



NOZZLES

# VISCOMAT VANE

## FEATURES

- VERSATILITY
- MOBILE AND READY TO USE
- MULTIPURPOSE PUMP
- ADJUSTABLE BYPASS

The PIUSI VISCOMAT VANE is an electric vane pump suitable for all those applications where it is necessary to apply a transfer system with high suction capacity in order to transfer fluids with low viscosity up to 500 cSt. The pump is fitted with an asynchronous and self-ventilating motor, closed and available in different voltages and frequencies in order to adapt to any working condition.

### PERFORMANCE

UP TO

**50 L/MIN**

FLOW RATE

**AC**

**CONTINUOUS DUTY**

POWER

UP TO

**500 CST**

VISCOSITY



VISCOMAT VANE



### PACKAGING

CODE	WEIGHT		PACKAGING			N. BOXES / EUROPALLET	
	KG	LBS	MM	INCH	PCS/BOX	✈	🚚
<b>VISCOMAT 70</b>							
FO033490A	14,1	31,1	355X185X285	-	1	60	72
FO033190A	14,1	31,1	350X200X280	-	1	60	72
<b>VISCOMAT 90</b>							
FO0303M00	14,1	31,1	350X200X280	-	1	60	72
000303000	14,1	31,1	350X200X280	-	1	60	72

The engine is considered exempt from energy efficiency specifications in accordance with Article 2(2)(a) of Regulation (EU) 2019/1781



FILTRATION



TANK MONITORING



HOSE REEL



ACCESSORIES



MERCHANDISE



ANY BIODIESEL



AIR



ANTIFREEZE



AdBlue®



BIODIESEL



DIESEL



FOOD



GASOLINE



GREASE



KEROSENE



OIL



WATER



WINDSCREEN

### CHART

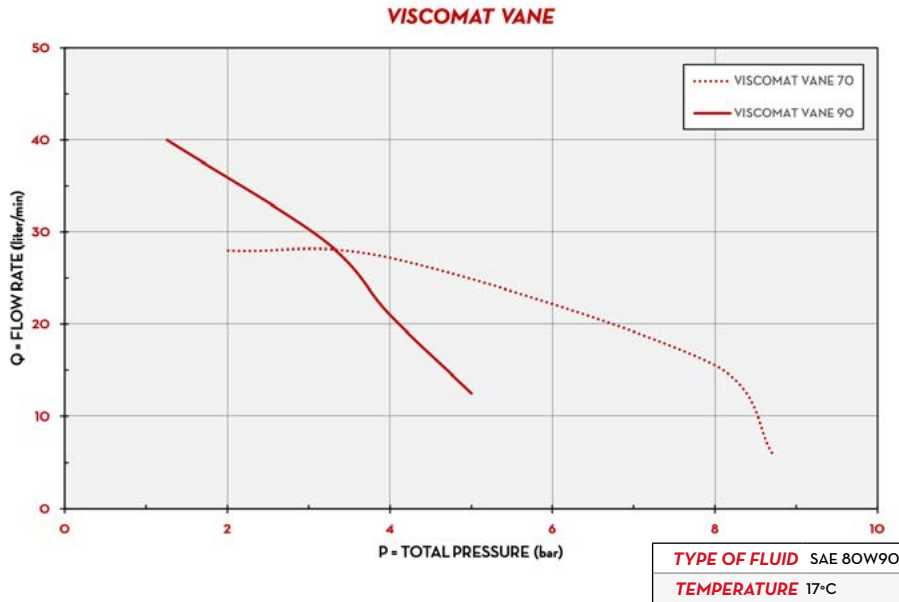

### DIMENSIONS

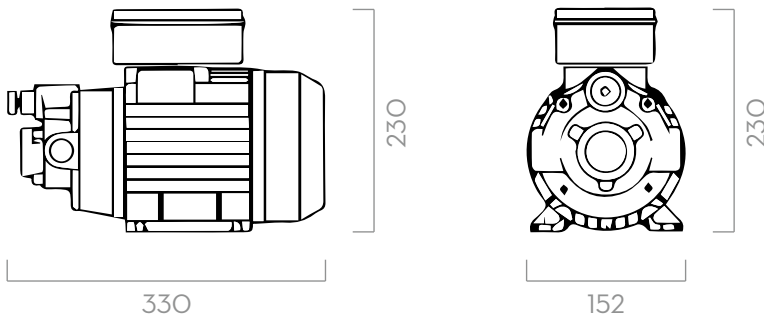

Dimensions expressed in millimeters

### IN THE BOX

- VISCOMAT VANE PUMP
- INSTRUCTION MANUAL

### DETAILS

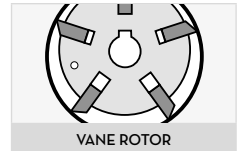

### MATERIALS

- BODY: CAST IRON
- ROTOR: SINTERED STEEL
- VANES: TECHNOPOLYMER
- SHAFT: STEEL



- SUCTION HOSE Ø 1" MIN,
- MAX SUCTION HEIGHT:
  - 2M (7FT) W/O NO BACK VALVE
  - 4M (14FT) W NO BACK VALVE



### TECHNICAL DATA

CODE	DESCRIPTION	FLUIDS TYPE	FLOW RATE		PRESSURE		VOLTAGE				RPM	INLET OUTLET		ADJUSTABLE BYPASS VALVE
			L/MIN	GPM	BAR	PSI	SINGLEPHASE MOTOR V/Hz	THREEPHASE MOTOR V/Hz	POWER WATT	AMP. MAX.		BSP		
<b>VISCOMAT 70</b>														
FO033490A	VISCOMAT 70 M 230/50-60	D O B	25	7	6	85	230/50-60	-	1200/1100	5,5 - 5,1	1470/1650	1"	YES	
FO033190A	VISCOMAT 70 T 400/50-60	D O B	25	7	6	85	-	400/50 - 400/60	650/1000	2,2 - 3,1	1450/1750	1"	YES	
<b>VISCOMAT 90</b>														
FO0303M00	VISCOMAT 90 M 230/50-60	D O B	50	13	5	71	230/50-60	-	1350/1600	6,2 - 4,9	1400/1600	1"	NO	
000303000	VISCOAMT 90 T 400/50	D O B	50	13	5	71	-	400/50	2000	5	1450	1"	YES	

UPON REQUEST IT IS AVAILABLE WITH DIFFERENT VOLTAGE AND FREQUENCY

## VISCOMAT VANE